

KALEJA GmbH
D-73553 Alfdorf

**Motor control for brush sticking
 direct current DC motors 24VDC**

Model for switched currents up to 5A

Control with the following functions:

- direction reversal
- speed control
- start- stop - ramp function
- I x R compensation

Snap / fit for DIN rail EN 50022

Model with: 22,5mm

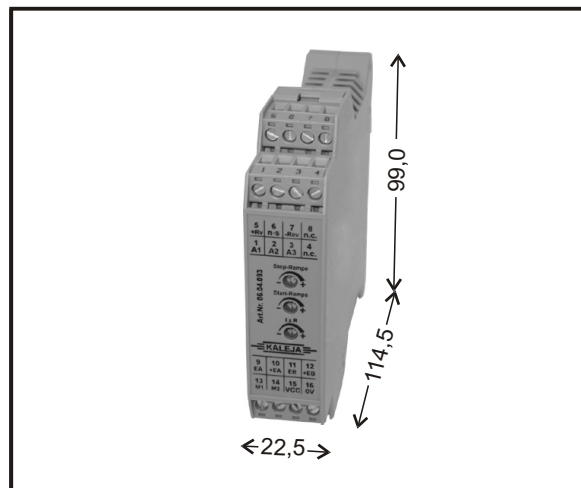

Short Designation Type		Nominal voltage: 24VDC M-RA-5-24
Order no. (Art.No.)		06.04.093
Specifications: input circuit		
Nominal voltage / control voltage	24 VDC	
Nominal voltage range min. / max.	19V to 30VDC	
Input current at Un	10mA	
Analogue input rotational speed control	0V to 10VDC	
External potentiometer for speed control	10 KOhm	
Specifications: output circuit		
Timing of the Start- Stop- Ramp		0,1 sec. to 10 sec.
Max. rated load current		8A / 5A
Current sensing by short / circuit		95 typ. (45 - 140A)
Deactivation at short circuit		80 - 400 µs
Dynamic break		Yes switching ON / OFF
IxR compensation (speed compensation by increasing resistance)		Yes
Power driver		MOS-FET
Further specifications		
Allowable ambient temperature		-20°C to + 60°C
Overload protection		Yes
DIN VDE-regulations		VDE 0110, 0160 sep. Parts
Mounting position / installation		Snap-fit, modular
Type of connection: screwed connection / plug in		Single wire 4mm², finely 2,5mm²
Case dimensions: w x h x d		22,5mm x 114,5mm x 99mm

Notes

Input A1 to A3:

The control is conceived for direction of rotation reversal. The clamp 1 (A1) and the clamp 2 (A2) are responsible for the starting functions of the motor. If A1 is powered, the motor starts, if A2 is powered the engine starts into the other direction of rotation. **A1 and A2 may be activated not at the same time.** When switching off the motor the dynamic brake is activated if the clamp 3 (A3) is not powered (engine coil is switched to GND (0V). The motor stops immediately. If the clamp 3 (A3) is powered, the dynamic braking is deactivated and the motor is not braked.

Input EA and EB:

If external limit switches are needed, the clamps 9 (EA) and 11 (EB) are responsible. At the clamps 10 (+EA) and 12 (+EB) supply voltage is made available.

Input n-Soll:

At the clamp 6 (n-s) the motor speed can be controlled (SPS 0-10VDC) or with an external 10 KOhm potentiometer. For the potentiometer a reference voltage of 10VDC is provided by the control system at clamp 5 (+Rv) 10VDC and at clamp 7 (-Rev) you have 0V.

Start / Stop - Ramp:

At the front side of the control there are 2 trimmers placed. With this trimmers you could adjust the time for start ramp as well as for stop ramp. The times can be adjusted independently (0,1 to 10 sec.).

IxR Compensation:

With load differences at the motor IxR compensation regulates the motor speed on synchronisation. With the trimmer IxR at the front side of the control, the compensation can be adapted to the motor.

Standard wiring

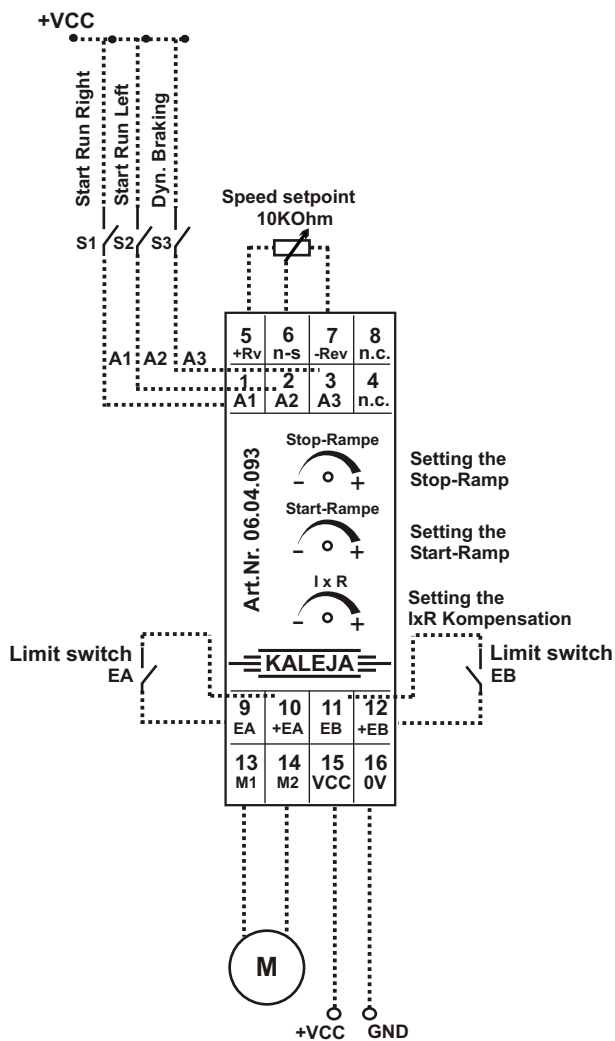

SPS - wiring

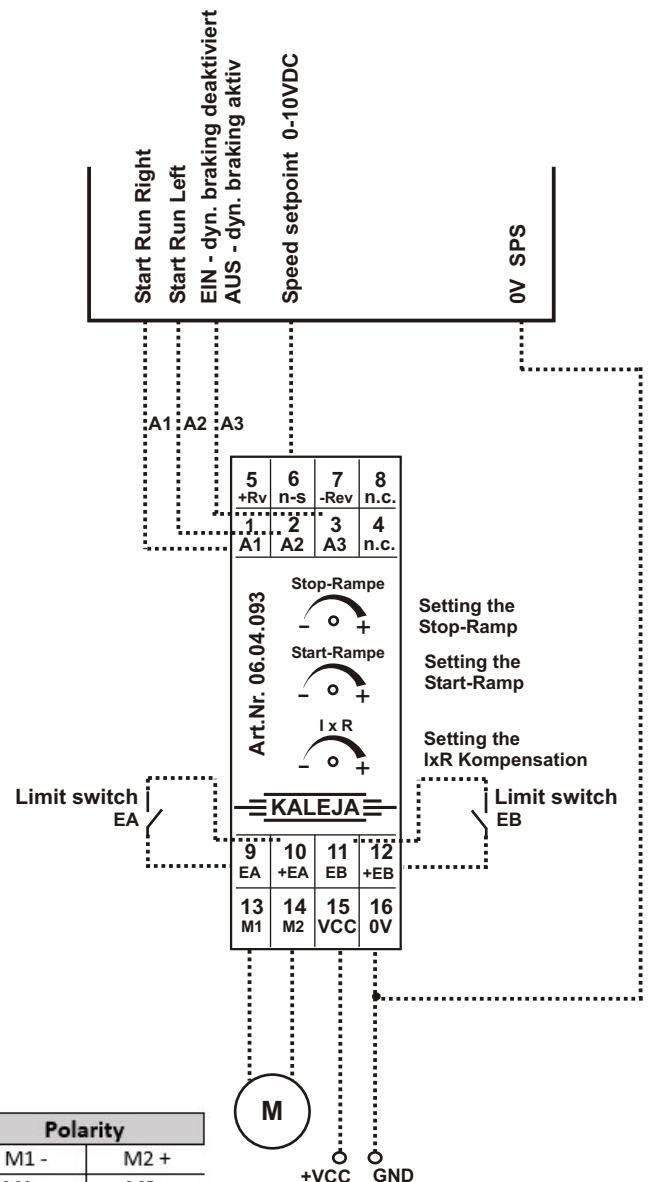

Direction of Travel	Polarity	
Right (A1)	M1 -	M2 +
Left (A2)	M1 +	M2 -